

BEAM LIGHT

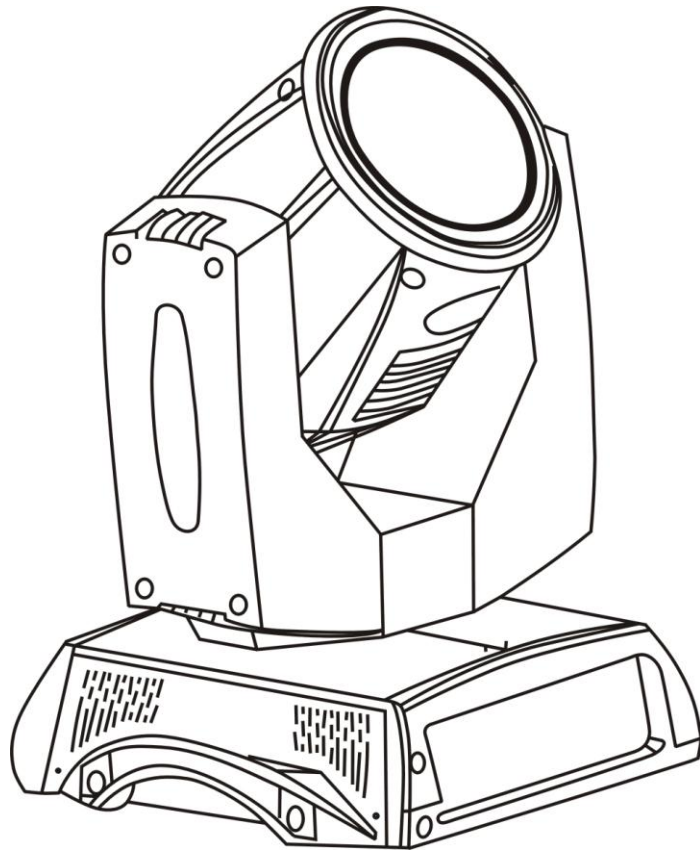

USER MANUAL

ITEM No.: 200W/230W

Please read over this Manual before Operating the Light Fixture

First, thank you for purchasing our professional lighting equipments.

This manual includes important information of how to install and use the fixture safely. Please install and operate it correctly as required, and keep the manual properly in case of need.

This moving head light is the perfect combination of humanity and industrial design with beautiful modeling. The body of the light is made of aluminum alloy and high temperature resistant engineering plastic materials with wonderful cooling effect. And the transmission mechanism adopts electronic positioning technology. This product fully meets the CE standard which employs the international standard signal control DMX512, and is widely used in TV station, disco, dance hall, night club and other indoor or outdoor shows.

This product is in good condition and packed well before shipping. Please follow strictly the stated warning and instructions when operating. It is not guaranteed by our company for any damage or breakdown of the product caused by misuse the product before reading the operation manual.

Warnings:

Please check if there is any transportation damage before using. And if there is any damage, please stop using it, and contact the distributor or manufacturer as soon as possible. Please keep it away from Combustible materials, and unlock the X-, Y-axis before using. The fixture should be installed in places with good ventilation, keep it away from the wall at least 10cm above, and then check if the fans are in good conditions.

Please don't project the light beam on the combustible directly, and keep the fixture at least 12m away from the projection objects.

Please don't look directly into the light source lest any damage to your eyes. And please make sure the using power voltage is in accordance with the stated voltages before using.

Attention: Please power off before installing, repairing or cleaning the fixture.

1. Operation Modes:

Touch	Turning Wheel	Function
“Up” button	Turn left	Select、Edit
“Down” button	Turn right	Select、Edit
“Confirm” button (“OK”)	Press the wheel	Start running Start editing、Stop editing
“Return” button	Press the wheel under Return manual	Return to previous page

For example, how to change DMX address?



1. Please press “Setting” in the main interface to enter “setting” interface.
2. There are 4 touch key-presses on the right side, namely, “Up” “Confirm” “Down” “Return” buttons.
3. Please press “Up” or “Down” keys to enter “DMX address”.
4. Please press “Confirm” to edit.
5. Please press “Up” or “Down” keys to change DMX address (the new DMX address would be saved automatically and start to run)
6. Please press “Confirm” to exit editing.
7. Please press “Return” to exit main manual.

Operation modes for turning wheel:

1. Please press “Setting” button under the main interface, and turn the wheel.
2. Please press the wheel to enter “setting” interface.
3. Please turn the wheel to enter “DMX address” interface under “setting” interface.
4. Please press the wheel to edit.
5. Please turn the wheel to change the DMX address.
6. Please press the wheel to exit editing after the modification.
7. Please turn the wheel to enter “Return”, and then press the wheel to return the main interface.

2. Control Panel Instructions:

2.1. Main Interface



The 3 buttons on the up right corner are for language switch and screen rotation.

The 4 buttons on the bottom are for sub-interfaces.

How to use the wheel to control the sub-interface? Please see as follows::

For “Up” button: Please turn left.

For “Down” button: Please turn right.

For “Confirm” button: Please press the wheel.

Operation of Dialog by turning wheel:

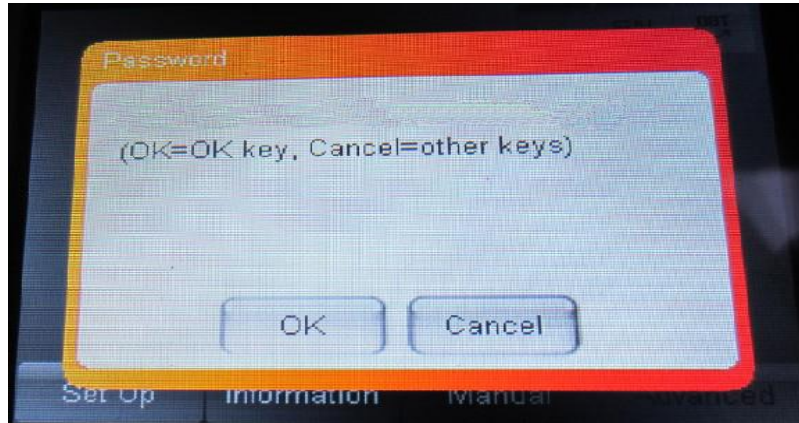

If for “YES”, then press the wheel. And if for “No”, then turn the wheel.

2.2. Setting of Interface

Options	Instructions	
Running Mode	DMX	Slave machines: accept DMX signals from controller or Master machine.
	Auto	Master-Slave: running automatically, and send DMX signals to slave machines. Attention: If need to check the light effects, please power on the lamp first to enter self-propelled state.
DMX Address	1-512	Press “Confirm” button to edit. First is for “ hundred's digit ”, and press “Up” and “Down” to change the address codes. Press “Confirm” button the second time to edit “ ten's digit ”, and press again the “Confirm” button to edit “ unit's digit ”. Please press it again to exit editing.
Channels	16	17-20 CH Invalid
	20	17-20CH to control speed (please refer to Channel chart)
X Reverse	off	
	on	
Y Reverse	off	
	on	
XY Exchange	off	
	on	Exchanging XY channels (Pan/Tilt fine included)

XY Encorder	on	Use Encorder (optocoupler) to judge out of sync or not, and self-correct the position.
	off	Don't use Encorder (optocoupler) to rectify the position
No DMX signal	stay	Stay the same
	reset	Stop running
Screen Save mode	on	Screen light off automatically after 30secs
	off	Screen stay on
Starting up	off	Reset directly when power on, lamp stay off (need to operate the manu or console to light up the lamp)
	on	Lamp on when power on, and reset after the lamp is fully lighted up.
Recover default setting		Press "Confirm" button to see the confirm dialog, and press "Confirm" button again to recover default setting.

2.3.Information Interface

Options	Illustrate
Software version	The current software version
Total time	Total time (accurate to the minute)
The use of time	Since the boot (accurate to the minute)
DMX Channel	Click here to go to the sub-interface, numerical and percentage display channel for viewing.
System error records	If the red ERR indicator light, illustrate lamps run error, Details Click here go to the sub-interface view. After you finish, press "OK" key to delete error records. Note: sometimes it is not Hall or optocoupler installation problems, but the motor line reversed.

2.4. Manual Control Interface

This interface is used to control the current lighting, neither belong to slave state (does not receive DMX signal), nor belong to the host state (do not send DMX signal)

Options	Illustrate	
Reset	Press the OK button after see a confirmation dialog box, click "OK" key to enter the reset interface, all motor reset again.	
Color Wheel	Press "Confirm" button to edit. First is for " hundred's digit ", and press "Up" and "Down" to change the address codes. Press "Confirm" button the second time to edit " ten's digit ", and press again the "Confirm" button to edit " unit's digit ". Please press it again to exit editing.	
Gobo Wheel Speed	0-255	
Bulb Control	Turn on	
	Turn off	

2.5. Advanced Interface

The code is “up down up down”, and code for the wheel is “ left right left right”.

Manu Operation modes: Press “Up” to see the first “*”, and press “Down” key to see the second “*”, and press “Up” to see the third “*”, and press “Down” key to see the fourth “*”, and last press “Confirm” key to enter password confirmation.

Turning wheel Operation modes: Turn one bit left to see first “*”, and Turn one bit right to see the second “*”, and turn one bit left to see the third “*”, and Turn one bit right to see the fourth “*”, and last press the wheel to enter password confirmation.

Options	Instructions
Touch Screen Calibration	Please touch the place according to the prompt of the cross cursor in the Calibration interface. If the 4 values received the right data, then save the data. If failed, it will keep repeating. Please press “Confirm” button to stop Calibration any time.
Reset Calibration	When enter sub-menu, the reset location of X.Y axis motors is adjustable. It is not able to edit “ unit's digit ”, “ ten's digit ” or “ hundred's digit ” or long-time press for Reset Calibration which needs to be calibrated step by step, which is different from address code and channel values. Attention: Please don't conduct Reset Calibration, when the motors are working. And please reset the fixture before Reset Calibration when necessary.

CHANNEL	CHANNEL MODE	
	16	20
1	COLOUR WHEEL	COLOUR WHEEL
2	STOP/STROBE	STOP/STROBE
3	DIMMER	DIMMER
4	STATIC GOBO CHANGE	STATIC GOBO CHANGE
5	PRISM ROTATION	PRISM ROTATION
6	PRISM ROTATION	PRISM ROTATION
7	EFFECTS MOVEMENT(UNUSED)	EFFECTS MOVEMENT(UNUSED)
8	FROST	FROST
9	FOCUS	FOCUS
10	PAN	PAN
11	PAN FINE	PAN FINE
12	TILT	TILT
13	TILT FINE	TILT FINE
14	FUNCTION(UNUSED)	FUNCTTON(UNUSED)
15	RESET	RESET
16	LAMP CONTROL	LAMP CONTROL
17		PAN-TILT TIME

18		COLOUR TIME
19		DIMMER-PRISM-FROST TIME
20		GOBO TIME

COLOER WHEEL-channel 1

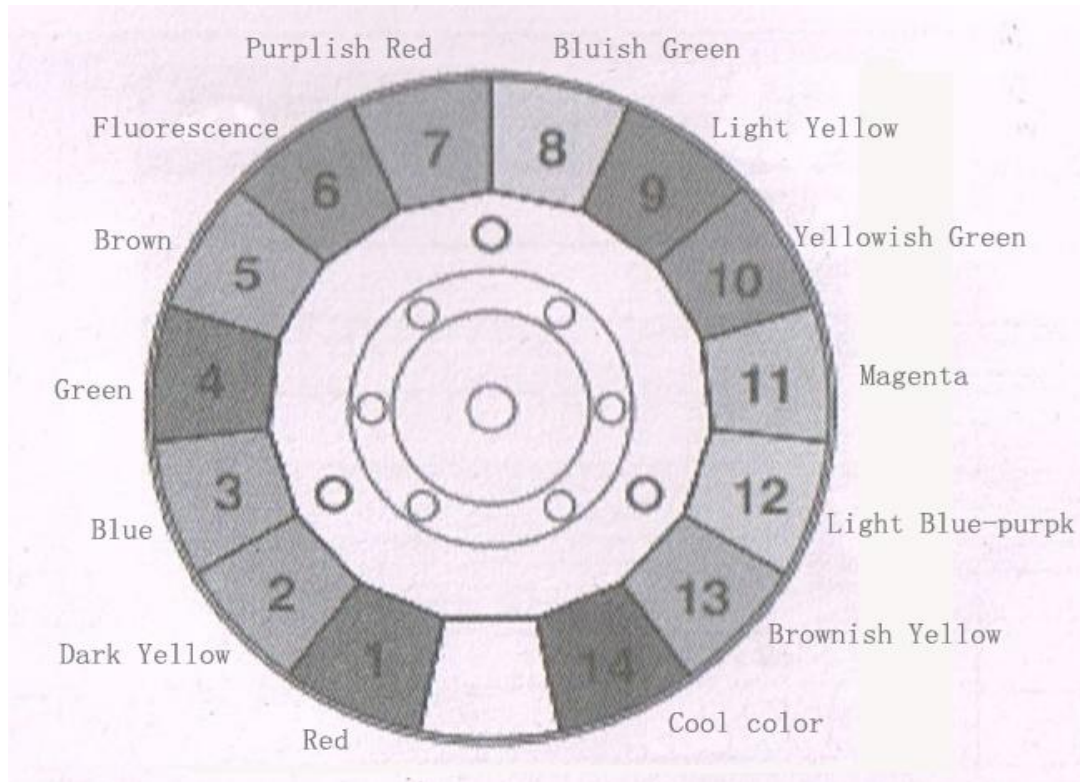

BIT	EFFECT	备注
255	FAST ROTATION	
.....	
150	SLOW ROTATION	
145	COOL COLOR +WHITE	In order to facilitate memory, color value is always a multiple of five. Color ratio can be adjusted, for example: when the value is five, so it should be 50% white, dark red 50%, if the value is 4, so it should be 60% white, dark red 40%: If the value is six, so it should white 40% dark, red 60%.
140	COOL COLOR	
135	BROWNISH YELLOW+COOL COLOR	
130	BROWNISH YELLOW	
125	LIGHT BLUE-PURPK+BROWNISH YELLOW	
120	LIGHT BLUE-PURPK	
115	MAGENTA+LIGHT BLUE-PURPK	
110	MAGENTA	
105	YELLOW GREEN+MAGENTA	
100	YELLOW GREEN	
95	LIGHT YELLOW+YELLOW GREEN	
90	LIGHT YELLOW	
85	BLUISH GREEN+LIGHT YELLOW	
80	BLUISH GREEN	
75	PURPLISH RED+BLUISH GREEN	

70	PURPLISH RED	
65	FLUORESCENCE+PURPLISH RED	
60	FLUORESCENCE	
55	BROWN+FLUORESCENCE	
50	BROWN	
45	GREEN+BROWN	
40	GREEN	
35	BLUE+GREEN	
30	BLUE	
25	DARK YELLOW +BLUE	
20	DARK YELLOW	
15	RED+DARK YELLOW	
10	RED	
5	WEITE+RED	
0	WEITE	

STOP/STOBE-channel 2

BIT	EFFECT	Remarks
252-255	OPEN	Controlled by a dimmer channel
239-251	RANDOM FAST STROBE	
226-238	RANDOM MEDIUM STROBE	
213-225	RANDOM SLOW STROBE	
208-212	OPEN	Controlled by a dimmer channel
207	FAST PULSATION	
.....	
108	SLOW PULSATION	
104-107	OPEN	Controlled by a dimmer channel
103	FAST STROBE	
.....	
4	SLOW STROBE	
0-3	CLOSED	

DIMMER-channel 3

BIT	EFFECT	Remarks
255	100%	

.....	
0	0%	

STATIC GOBO CHANGE-channel 4

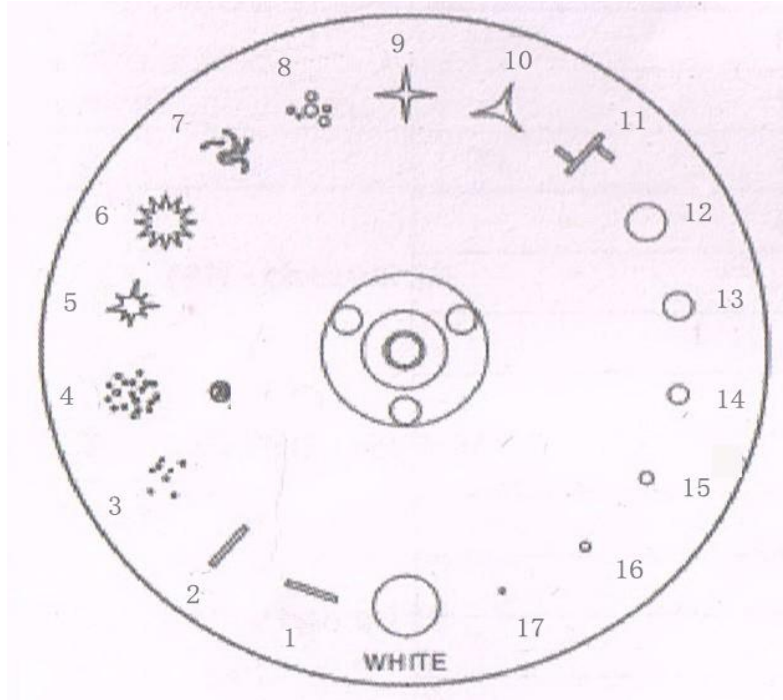

BIT	EFFECT	Remarks
255	GOBO 17 SHAKE,FAST SPEED	Every five values is correspond to a pattern.
.....	
251	GOBO 17 SHAKE,SLOW SPEED	
250	GOBO 16 SHAKE,FAST SPEED	
.....	
246	GOBO 16 SHAKE,SLOW SPEED	
.....	
180	GOBO 2 SHAKE,FAST SPEED	
.....	
176	GOBO 2 SHAKE,SLOW SPEED	
175	GOBO 1 SHAKE,FAST SPEED	
.....	
171	GOBO 1 SHAKE,SLOW SPEED	
170	FAST ROTATION	
.....	
135	SLOW ROTATION	
130-134	STOP	
129	SLOW ROTATION	
.....	
90	FAST ROTATION	

85	GOBO 17	Value is always five multiple
80	GOBO 16	
75	GOBO 15	
70	GOBO 14	
65	GOBO 13	
60	GOBO 12	
55	GOBO 11	
50	GOBO 10	
45	GOBO 9	
40	GOBO 8	
35	GOBO 7	
30	GOBO 6	
25	GOBO 5	
20	GOBO 4	
15	GOBO 3	
10	GOBO 2	
5	GOBO 1	
0	WHITE	

PRISM INSERTION-channel 5

BIT	EFFECT	Remarks
128-255	PRISM INSERTED	
0-127	PRISM EXCLUDED	

PRISM ROTATION-channel 6

BIT	EFFECT	Remarks
255	FAST ROTATION	
.....	
193	SLOW ROTATION	
191-192	STOP	
190	SLOW ROTATION	
.....	
128	FAST ROTATION	
0-127	POSITION	

EFFECTS MOVEMENT channel 7(NOUSED)

FROST-channel 8

BIT	EFFECT	Remarks
128-255	FROST INSERTED	
0-127	FROST EXCLUDED	

FOCUS-channel 9

BIT	EFFECT	Remarks
255	100%	
.....	
0	0%	

PAN-channel 10

(.....)

PAN FINE-channel 11

(.....)

TILI-channel 12

(.....)

TILT FINE-channel 13

(.....)

FUNCTION-channel 14(NOUSED)

RESET-channel 15

BIT	EFFECT	Remarks
128-255	COMPLETE RESET	Reset is activated passing through the unused range and staying 5 seconds.
77-127	PAN/TILT RESET	
26-76	EFFECTS RESET	
0-25	UNUSED RANGE	

LAMP CONTROL-channel 16

BIT	EFFECT	Remarks
128-255	LAMP ON	Lamp switch passing through the unused range and staying 5 seconds.
10-100	LAMP OFF	

0-9	UNUSED RANGE	
-----	--------------	--

TIMING CHANNELS

	Timing Channel	Channel function	Remark
17	Pan-Tilt time	Pan-Tilt-(Pan fine-Tilt fine)	255 SLOW SPEED
18	Color time	Color wheel
19	Beam time	Dimmer-Prism-Frost	0 FAST SPEED
20	Gobo time	Static Gobo	

Control signal connection

XLR-XLR control cable from the DMX output of the controller connected to each projector DMX input port, and from the first fixture in the DMX output port connected to the second fixture in the DMX input port, and so on, until the All lighting connection is completed, and then plug the supplied loop connected to the signal output of the last fixture to complete the connection, as shown:

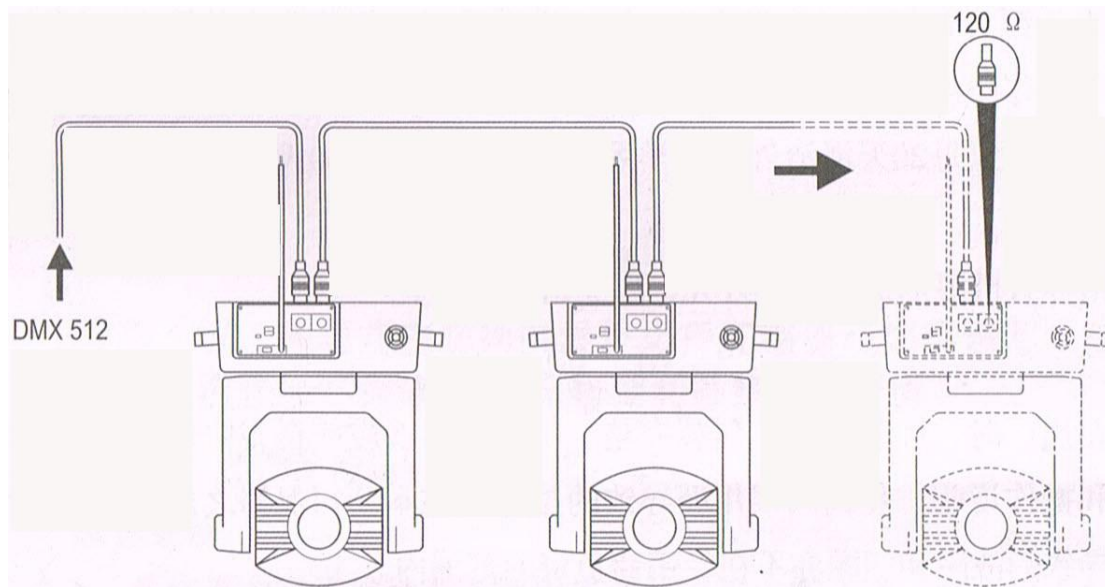

Note: Keep in mind that in the last fixture's output circuit connected to a plug, this circuit is connected to a 120 ohm resistor inserted between the CANON (XLR) plug 2 feet and 3 feet, this loop interpolation can effectively avoid the reflection signal generated by DMX512 signal in transfer input process.

The moving head light utilization the 3-pin XLR socket (head), if you are using the controller uses a 5-pin XLR socket (head), you must use a 5-pin to 3-pin converter cable, as shown below:

3-pin and 5-pin control cable plug (male and female) connector.

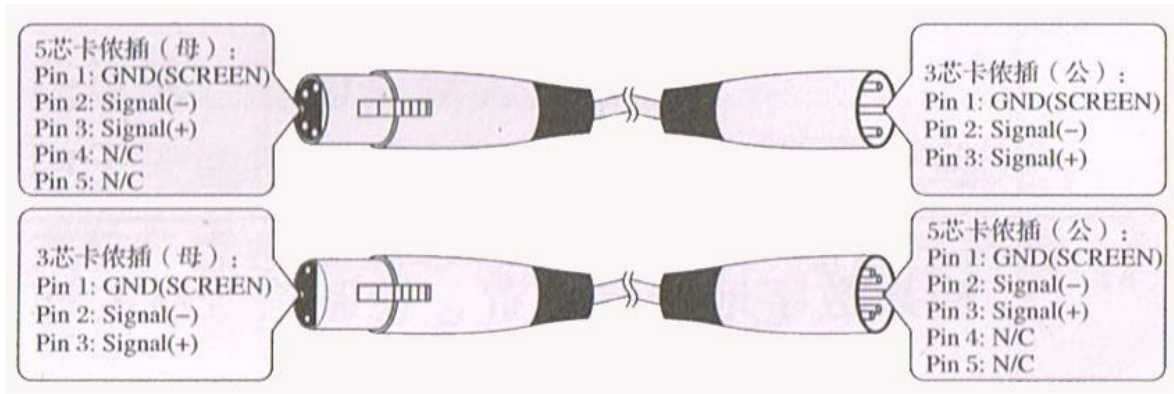

Three pin (Canon) DMX512 connector



Installation

UNPACKING AND PREPARATION

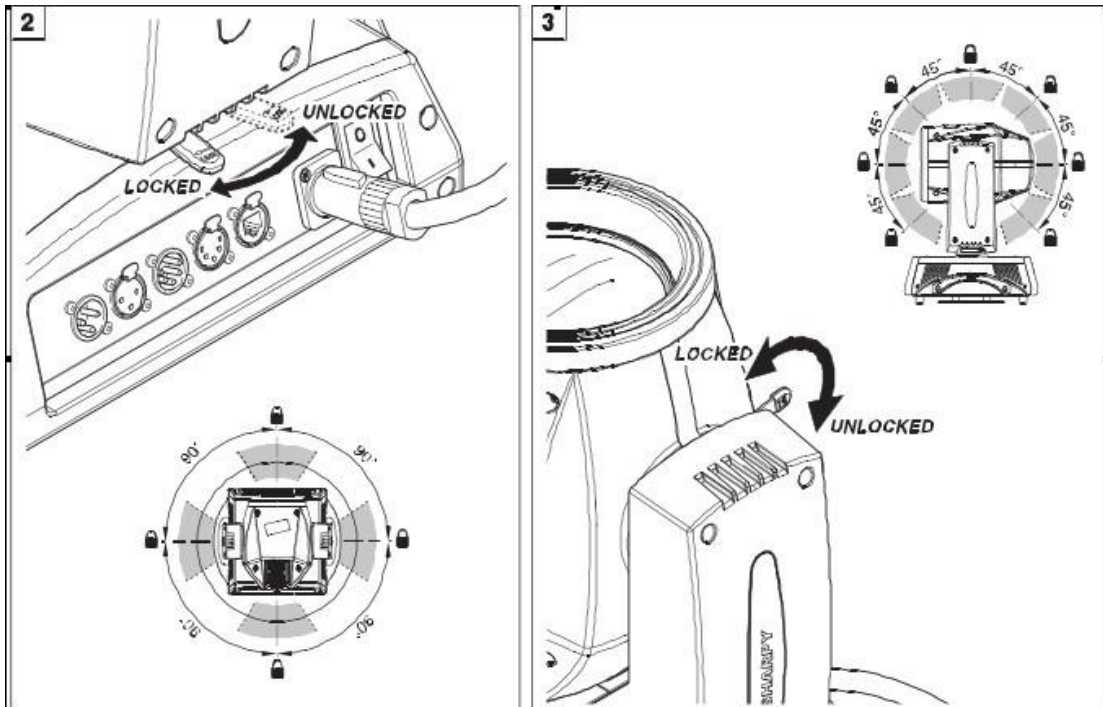
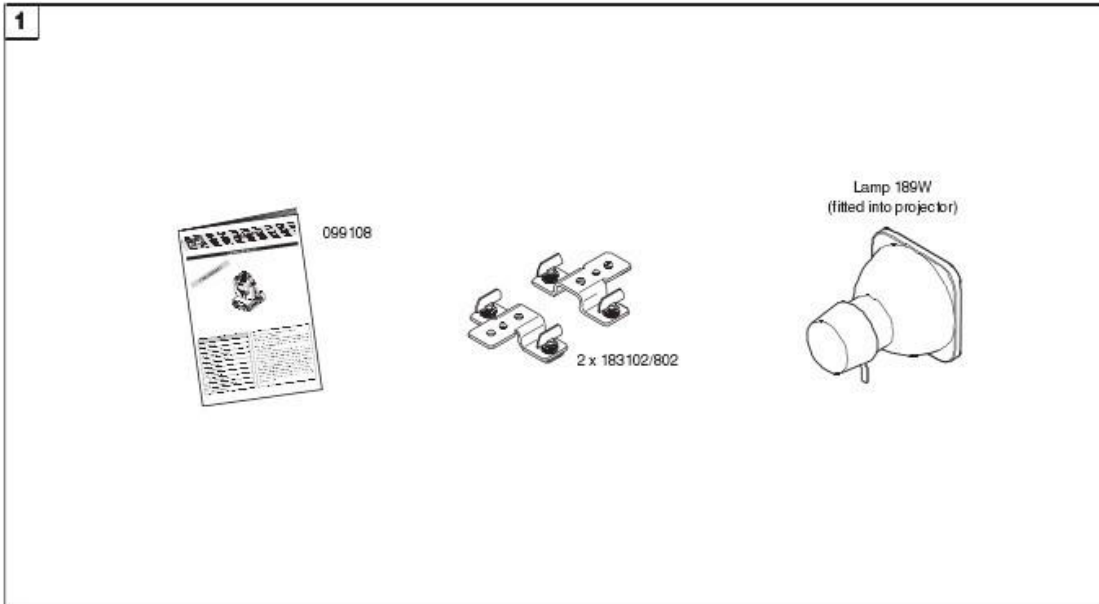

4

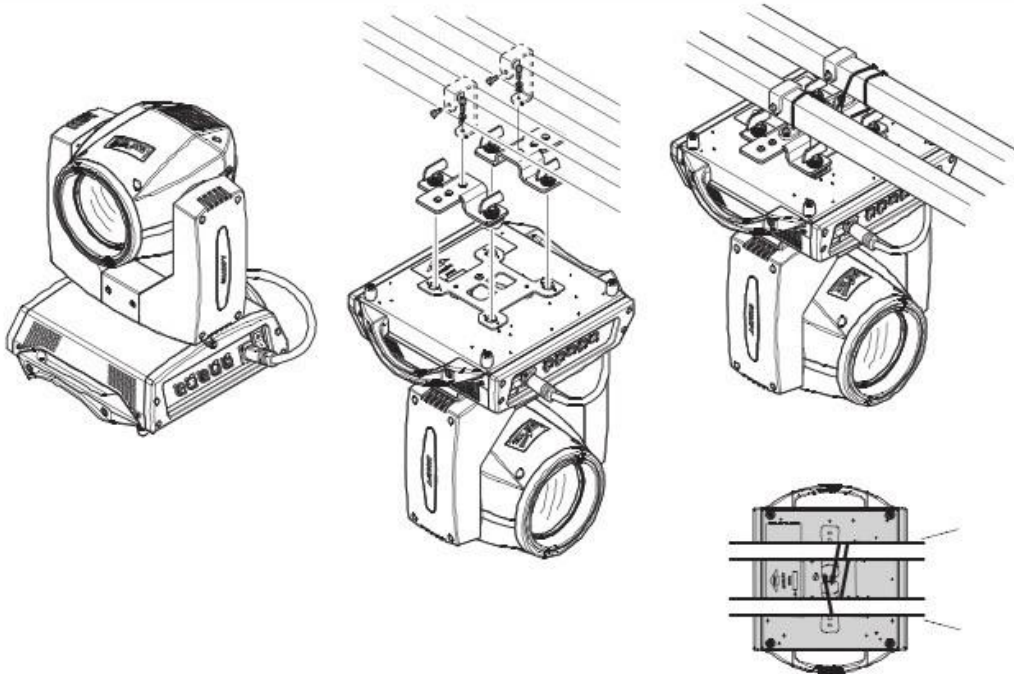

5

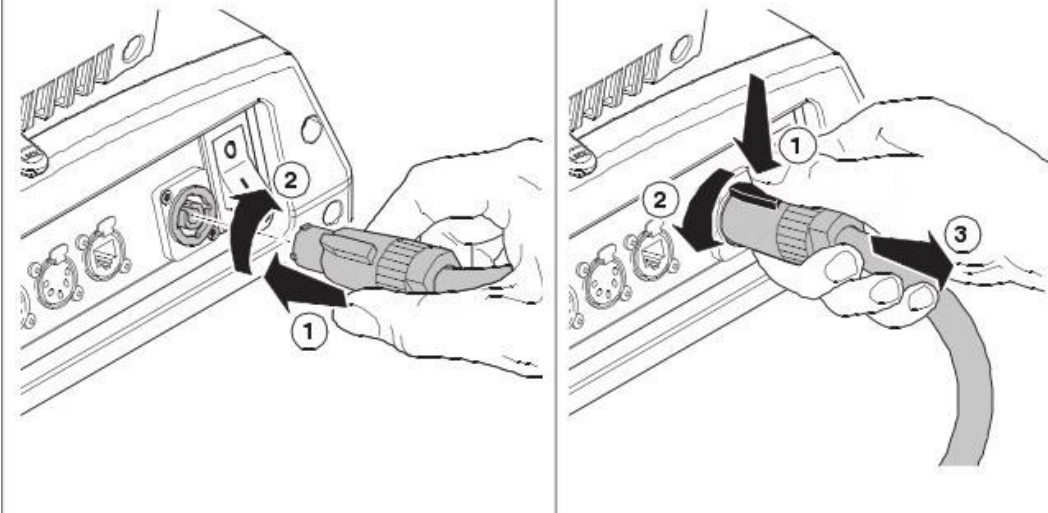

6

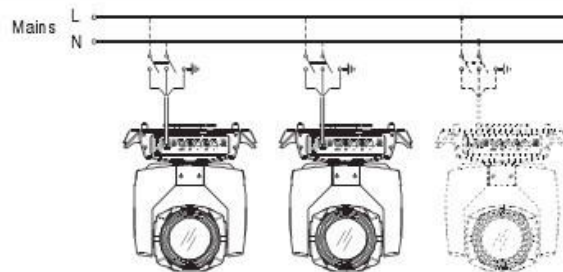

7

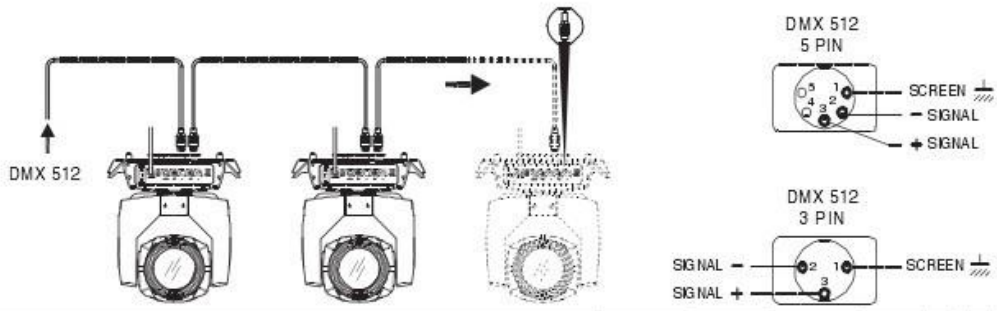

10

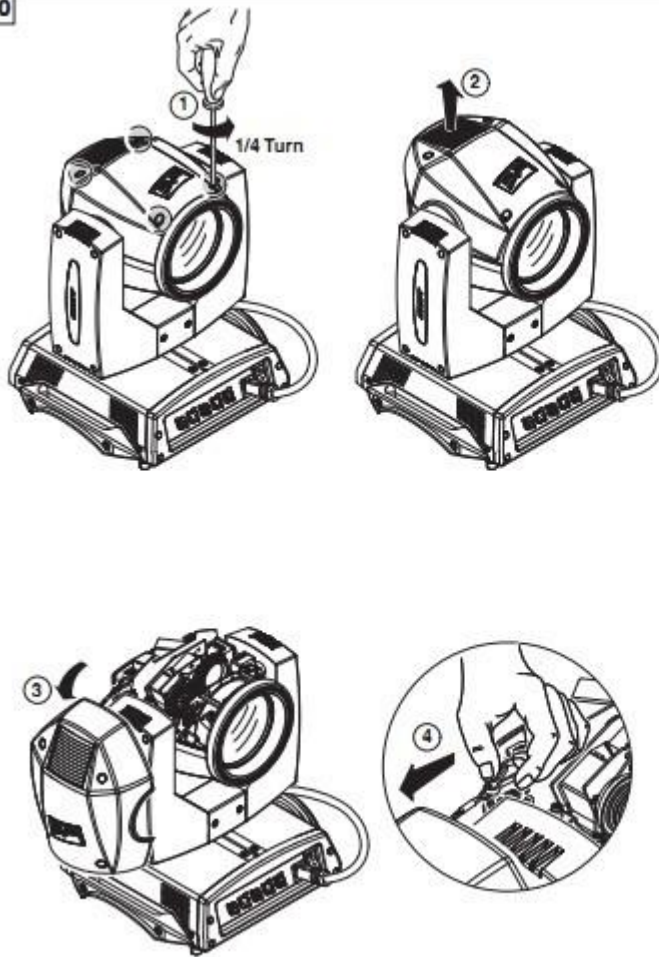

11

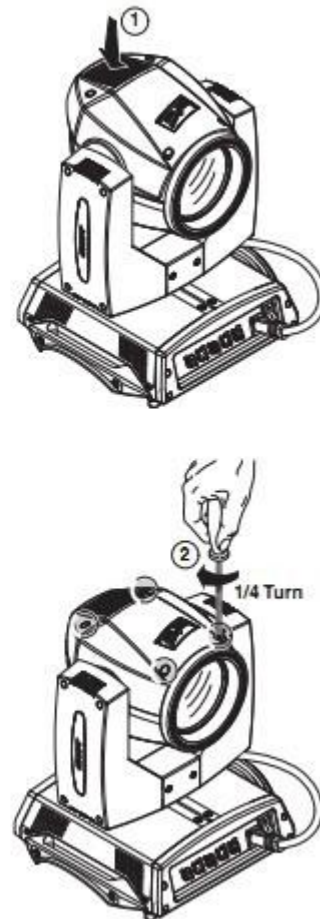

20

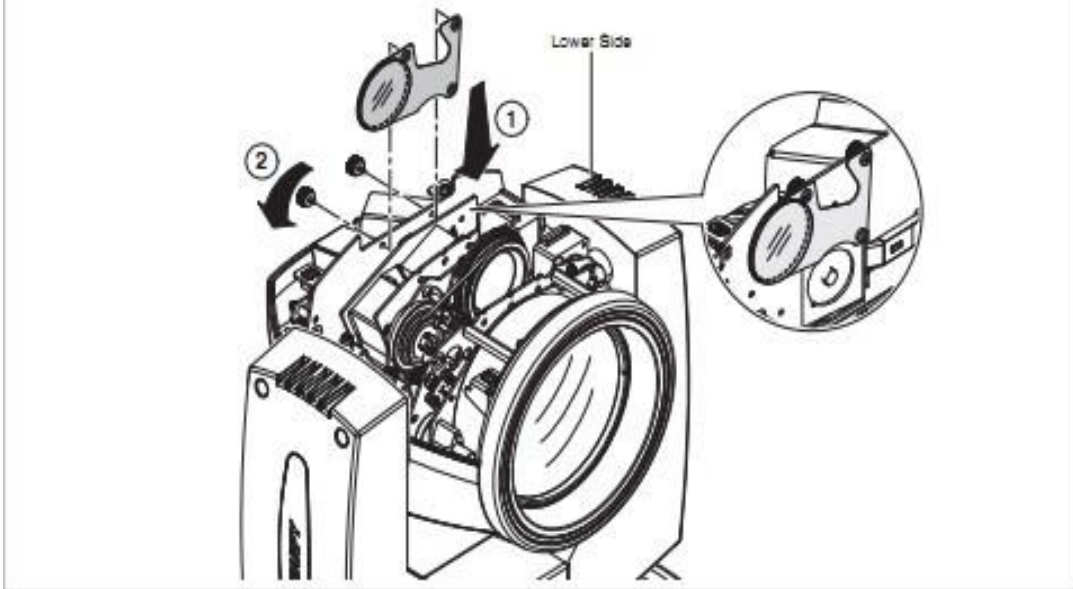

12

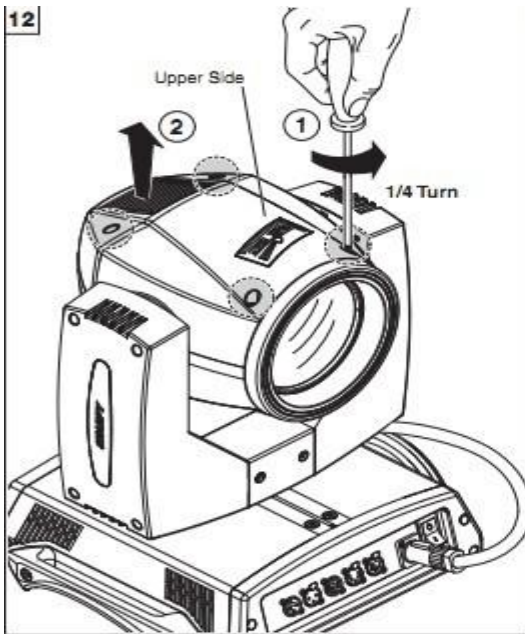

13

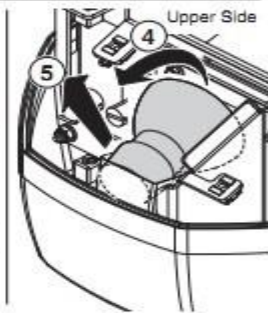
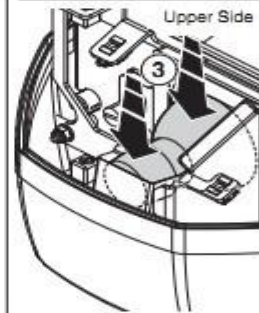
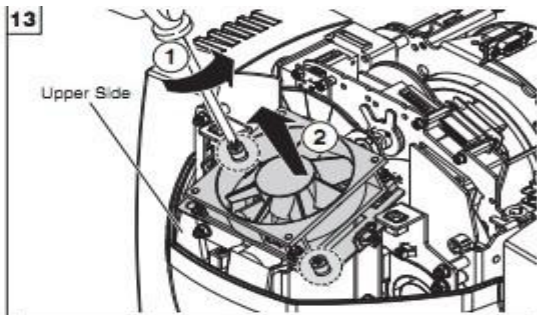

14

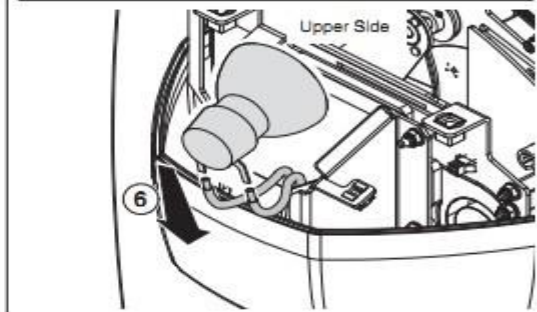
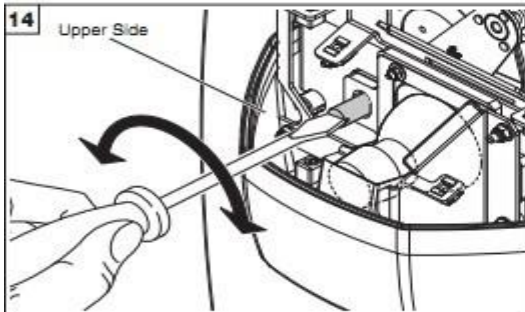

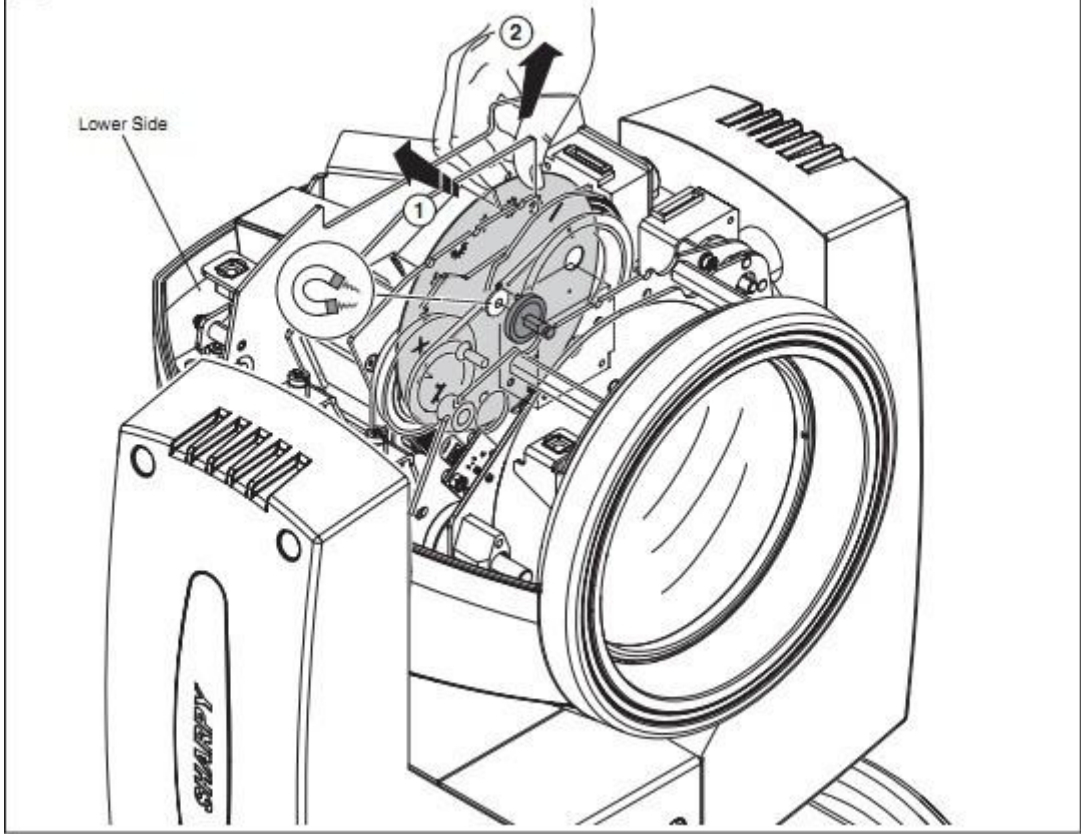

16

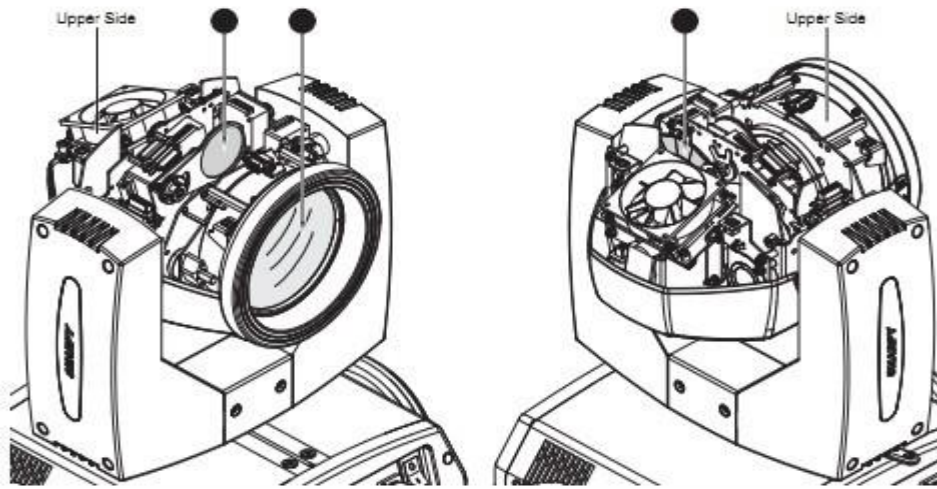
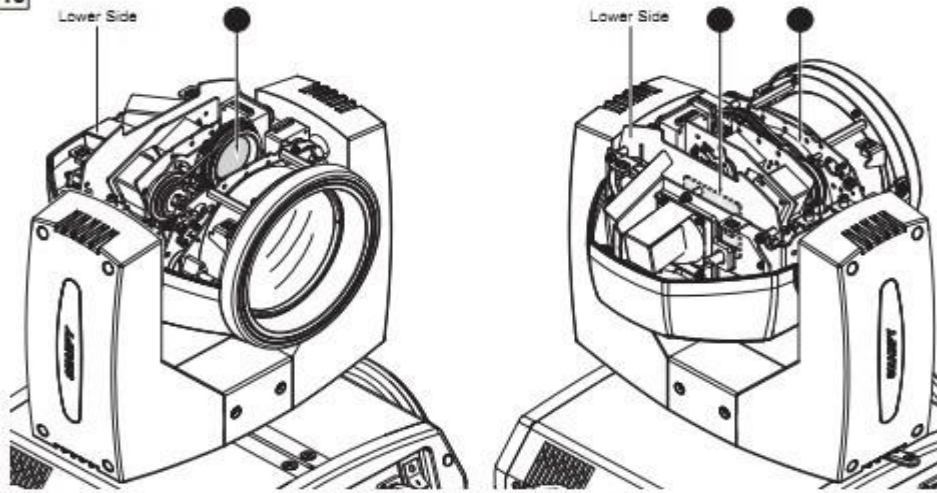

17

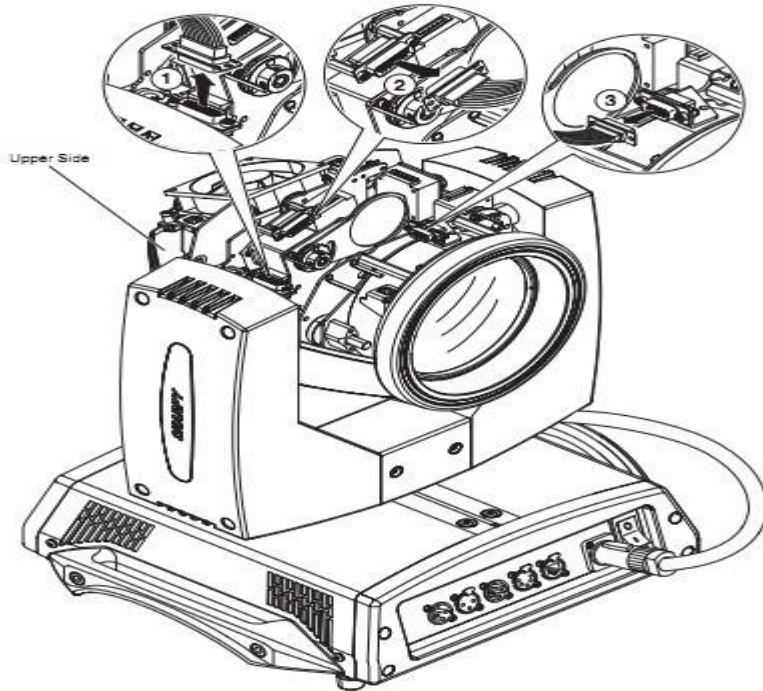

18

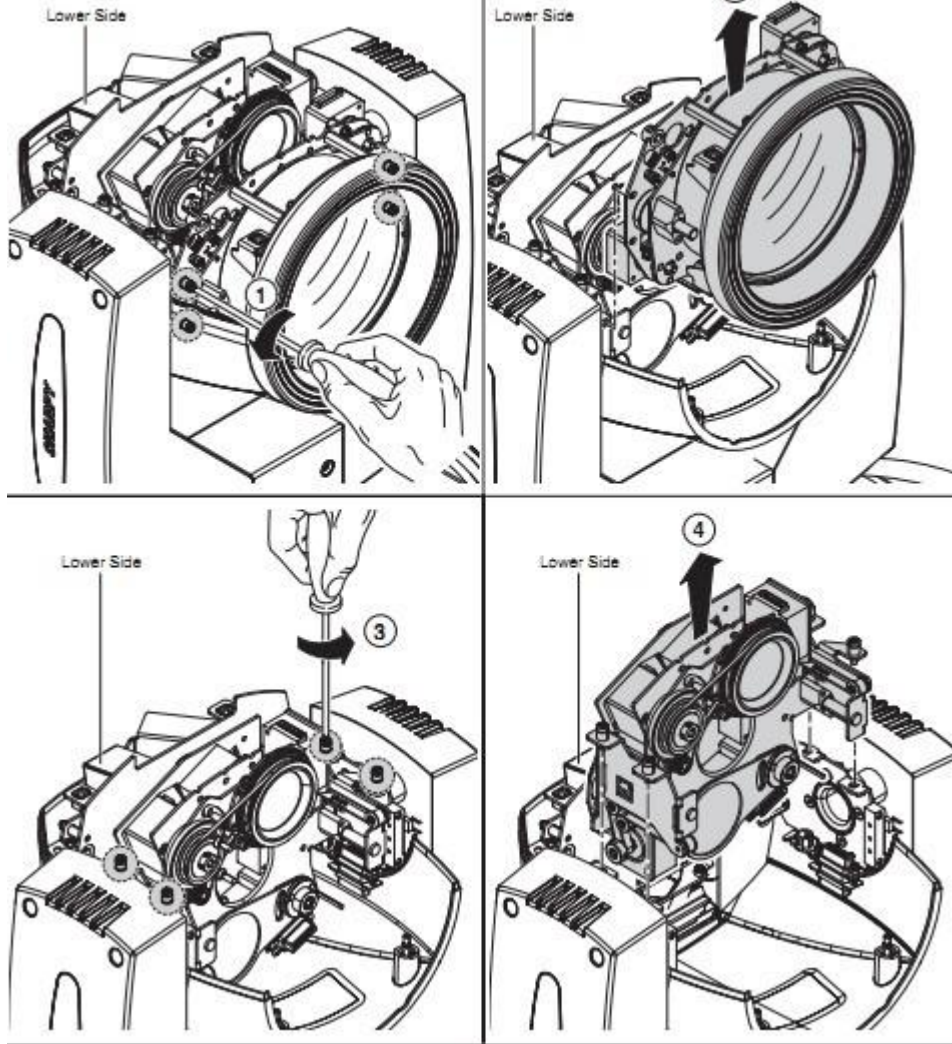

19

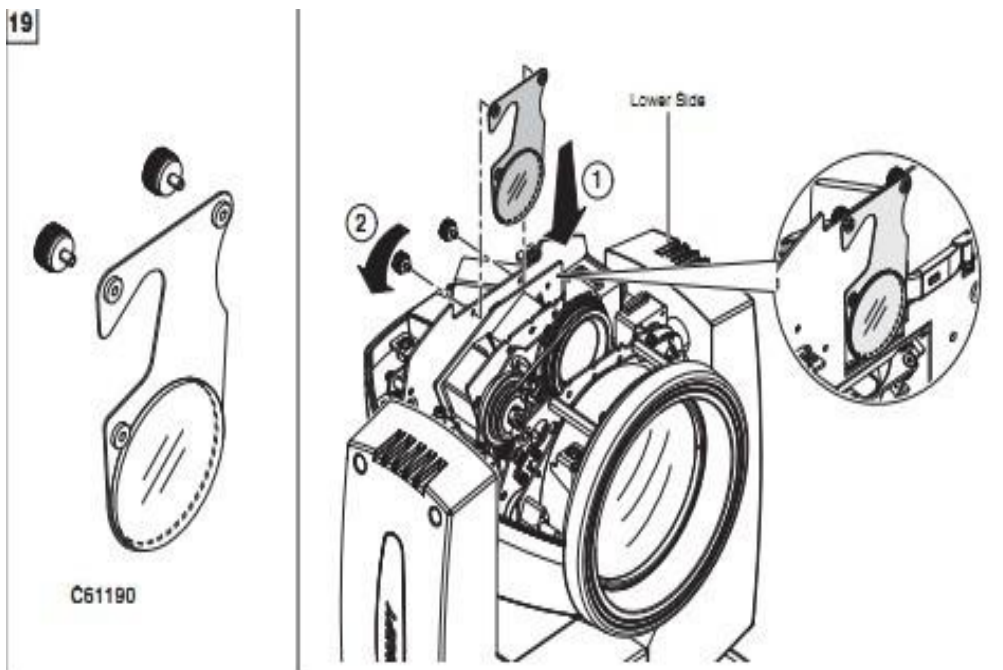

Protection and Maintenance:

You should exchange the lens timely, if you find the led has damaged. You should instant replacement the bulb when you find the deformation damage. The aging bulb has a danger of blowout. Please check the power fuse of light when the light unable to start. Install the corresponding specification fuse 6.35X32 T15A/250V when burning. Light has overheating protection device, Protection device will automatically cut off power supply when overheating. Please check the fan's operation, dirt jam between fan and fan nets when the situation happened. Find the reason and repair then restarting light. Attention only qualified technical personnel can repair it.

Light cleaning:

It is necessary to keep the light cleaning to ensure its reliable use. The fan should clean every 15 days. It needed to clean periodically of the internal and external optical lens, mirror and coating color filter in order to optimize the efficacy output. Do not use any chemical solvents containing to clean color filter. The frequency of cleaning is according to the operation of light and the environment of operation.

With soft cloth and general glass clean products clean the light. Suggest clean outside optical system every 20 days. Clean internal optical system at least every/60 days.

Don't use alcohol and organic solvent wipe to clean the shell of light lest cause damage.

Statement

a. The product is good performance and the package is complete before delivery. All users should strictly abide by the warnings and instructions stated above, any product which has been subjected to misuse and damage caused by the range beyond the Company within the warranty, caused by the failure to ignore the operation manual and problems not in the dealer responsible.

b. Company has the right of the interpretation about the manual item.

Problem solve method

Problem	Solve method
No supply power	Check the voltage of the power supply
Energized produce light, moving head light does not accept control instructions.	Check digit address code install, the control signal line connection
Projected images has light halo	Check the electronic focus channel value whether suitable for projection distance
The beam head very dim	Lamp may to arrived life, you should replace a new bulb, and check the optical components whether is clean

Note: qualified professionals could repair the lighting.

Product Warranty Card

Product Name: Product Item: Produce time: Buyer Purchase Time:

User: Sale Shop:

Company Name: Contact:

Address: Tel:

Contact:

Tel; Stamp:

Specification: Above blank by the end user and point-of-sale must truthfully fill, seal, or without warranty.

(Warranty period and terms as following)

Warranty:

1. In one year, starting from delivery day(except bulb and lens)
- 2.If the lights are non-working caused by quality, spare parts will be sent at first time and technical support will be provided by us, photos or videos will be required.
3. If the products need to be returned to us for repairing, the shipping costs will be covered by customers.

Non-warranty:

1. Damaged in carelessness use by buyer.
2. Broken or burnt caused by repairing the products by self without the instructions from seller

About non-warranty, customers can buy any spare parts about this product from us within 1year. If there is any upgrade for this item (materials, design etc), we don't take responsibility to inform buyer in time.

Tips: Please raise a complain to your local DHL company if there is any damage for the packages during shipping within 7days,and get a record number from the shipping company then contact us , refuse to sign in the receipt or sign in but talk to the carrier face to face, asking them to take a note when packages arrived.